

300Q-5 Quintuplex Plunger Pump

Specifications

Pump Size

maximum plunger size x stroke length, in.(mm):
4 x 5 (102 x 127)

Rated bhp at 400 rpm (kw): 300 (224)

Rated plunger load, pounds(Kg): 10,700(4853.5)

Maximum discharge pressure: psi(kPa)

"L" model: 1650 (11,375)

"M" model: 3000 (20,682)

"H" model: 5000 (34,470)

Crankshaft extension: in.(mm)

Diameter: 4.875 (123.8)

Length long side: 11 11/16 (297)

Length short side: 5 5/8 (143)

Keyway (width x depth):

1 1/4 x 5/8 (32 x 16)

Maximum recommended sheave

in.(mm): 58 (1473)

Minimum recommended sheave

in.(mm): 36 (914)

For larger sizes: **Contact Factory**

Pinion shaft extension,

if gear reducer is supplied, in.(mm)

For belt or chain drive:

Contact Factory

For direct drive: Diameter: 3.5 (88.9)

Length: 5 11/16 (145)

Keyway (width x depth):

7/8 x 7/16 (22.2 x 11.1)

Accessory gear reduction unit:

2.27:1, 2.89:1, 3.25:1, 3.36:1, 3.69:1,

4.38:1, 4.84:1, 5.63:1

Oil Capacity, gallons (L)

Crankcase: 12 (45.5)

Gear Reducer-varies with ratio:

3.5 to 6.5 (13.2 to 24.6)

Weight, pump only on

wood shipping skids, pounds (Kg)

"L": 7000 (3175)

"M": 6750 (3062)

"H": 6840 (3103)

Gear reducer, approximate, pounds (Kg):

1100 (499)

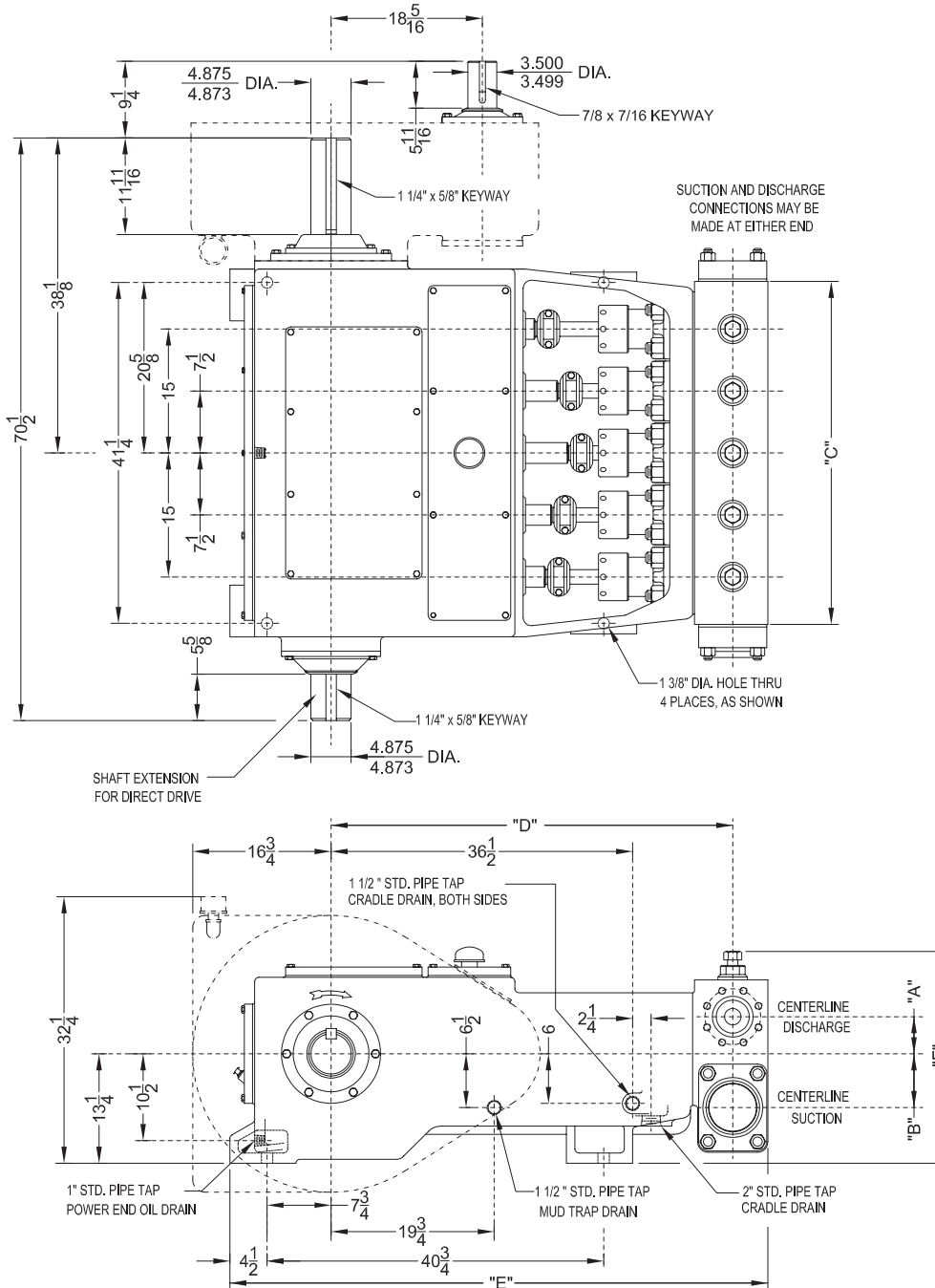

Pump Model	Flange Connections		Dimensions in inches (mm)					
	Discharge Connection Sizes	Suction Connection Sizes	A	B	C	D	E	F
300Q-5L	4 (101.6) API 2000 RJ	8 (203.2) ANSI 150 FF	6 1/4	9 1/8	43 1/4	49	68	25 1/8
300Q-5M	3 (76.2) NSD 5000 RJ	6 (152.4) NSD 600 RJ	4 1/2	6 1/2	41 1/2	48 5/8	65	25 7/16
300Q-5H	2 (50.8) ANSI 2500 RJ	6 (152.4) NSD 600 RJ	4 1/2	6 1/2	41 1/2	48 5/8	65 1/8	25 5/8

300Q-5 Quintuplex Plunger Pump

Performance Data

PUMP	English Units					100 RPM		200 RPM		250 RPM		300 RPM		350 RPM		400 RPM	
	Plunger Dia. In.	Plunger Area Sq. In.	BPD per RPM	GPM per RPM	Max. Press. PSI	BPD	GPM	BPD	GPM	BPD	GPM	BPD	GPM	BPD	GPM	BPD	GPM
300Q-5L	4.000	12.5664	46.6284	1.3600	851	4663	136.0	9326	272.0	11658	340.0	13989	408.0	16320	476.0	18652	544.0
	3.750	11.0447	40.9820	1.1953	969	4099	119.5	8197	239.1	10246	298.8	12295	358.6	14344	418.4	16393	478.1
	3.500	9.6211	35.6999	1.0412	1112	3570	104.1	7140	208.2	8925	260.3	10710	312.4	12495	364.4	14280	416.5
	3.250	8.2958	30.7820	0.8978	1290	3079	89.8	6157	179.6	7696	224.5	9235	269.3	10774	314.2	12313	359.1
	3.000	7.0686	26.2285	0.7650	1514	2623	76.5	5246	153.0	6558	191.2	7869	229.5	9180	267.7	10492	306.0
	2.750	5.9396	22.0392	0.6428	1650	2204	64.3	4408	128.6	5510	160.7	6612	192.8	7714	225.0	8816	257.1
300Q-5M	2.750	5.9396	22.0392	0.6428	1801	2204	64.3	4408	128.6	5510	160.7	6612	192.8	7714	225.0	8816	257.1
	2.500	4.9087	18.2142	0.5312	2180	1822	53.1	3643	106.2	4554	132.8	5465	159.4	6375	185.9	7286	212.5
	2.375	4.4301	16.4383	0.4795	2415	1644	47.9	3288	95.9	4110	119.9	4932	143.8	5754	167.8	6576	191.8
	2.250	3.9761	14.7535	0.4303	2691	1476	43.0	2951	86.1	3689	107.6	4427	129.1	5164	150.6	5902	172.1
	2.125	3.5466	13.1598	0.3838	3000	1316	38.4	2632	76.8	3290	96.0	3948	115.1	4606	134.3	5264	153.5
	2.000	3.1416	11.6571	0.3400	3000	1166	34.0	2332	68.0	2915	85.0	3498	102.0	4080	119.0	4663	136.0
300Q-5H	2.000	3.1416	11.6571	0.3400	3406	1166	34.0	2332	68.0	2915	85.0	3498	102.0	4080	119.0	4663	136.0
	1.875	2.7612	10.2455	0.2988	3875	1025	29.9	2050	59.8	2562	74.7	3074	89.6	3586	104.6	4099	119.5
	1.750	2.4053	8.9250	0.2603	4449	893	26.0	1785	52.1	2232	65.1	2678	78.1	3124	91.1	3570	104.1
	1.625	2.0739	7.6955	0.2245	5000	770	22.4	1540	44.9	1924	56.1	2309	67.3	2694	78.6	3079	89.8
	1.500	1.7671	6.5571	0.1912	5000	656	19.1	1312	38.2	1640	47.8	1968	57.4	2295	66.9	2623	76.5
Brake Horsepower Required						76	151	188	225	263	300						

PUMP	Metric Units					100 RPM		200 RPM		250 RPM		300 RPM		350 RPM		400 RPM	
	Plunger Dia. mm	Plunger Area cm ²	M ³ /Hr per RPM	L/Sec. per RPM	Max. Press. kPa	M ³ /Hr	L/Sec.	M ³ /Hr	L/Sec.	M ³ /Hr	L/Sec.	M ³ /Hr	L/Sec.	M ³ /Hr	L/Sec.	M ³ /Hr	L/Sec.
300Q-5L	102	81.073	0.3089	0.0858	5871	30.9	8.6	61.8	17.2	77.2	21.5	92.7	25.7	108.1	30.0	123.5	34.3
	95	71.256	0.2715	0.0754	6680	27.1	7.5	54.3	15.1	67.9	18.9	81.4	22.6	95.0	26.4	108.6	30.2
	89	62.072	0.2365	0.0657	7668	23.6	6.6	47.3	13.1	59.1	16.4	70.9	19.7	82.8	23.0	94.6	26.3
	83	53.521	0.2039	0.0566	8893	20.4	5.7	40.8	11.3	51.0	14.2	61.2	17.0	71.4	19.8	81.6	22.7
	76	45.604	0.1737	0.0483	10437	17.4	4.8	34.7	9.7	43.4	12.1	52.1	14.5	60.8	16.9	69.5	19.3
	70	38.320	0.1460	0.0406	11376	14.6	4.1	29.2	8.1	36.5	10.1	43.8	12.2	51.1	14.2	58.4	16.2
300Q-5M	70	38.320	0.1460	0.0406	12421	14.6	4.1	29.2	8.1	36.5	10.1	43.8	12.2	51.1	14.2	58.4	16.2
	64	31.669	0.1206	0.0335	15029	12.1	3.4	24.1	6.7	30.2	8.4	36.2	10.1	42.2	11.7	48.3	13.4
	60	28.581	0.1089	0.0302	16653	10.9	3.0	21.8	6.0	27.2	7.6	32.7	9.1	38.1	10.6	43.6	12.1
	57	25.652	0.0977	0.0271	18555	9.8	2.7	19.5	5.4	24.4	6.8	29.3	8.1	34.2	9.5	39.1	10.9
	54	22.881	0.0872	0.0242	20684	8.7	2.4	17.4	4.8	21.8	6.1	26.2	7.3	30.5	8.5	34.9	9.7
	51	20.268	0.0772	0.0215	20684	7.7	2.1	15.4	4.3	19.3	5.4	23.2	6.4	27.0	7.5	30.9	8.6
300Q-5H	51	20.268	0.0772	0.0215	23483	7.7	2.1	15.4	4.3	19.3	5.4	23.2	6.4	27.0	7.5	30.9	8.6
	48	17.814	0.0679	0.0189	26719	6.8	1.9	13.6	3.8	17.0	4.7	20.4	5.7	23.8	6.6	27.1	7.5
	44	15.518	0.0591	0.0164	30672	5.9	1.6	11.8	3.3	14.8	4.1	17.7	4.9	20.7	5.7	23.6	6.6
	41	13.380	0.0510	0.0142	34474	5.1	1.4	10.2	2.8	12.7	3.5	15.3	4.2	17.8	5.0	20.4	5.7
	38	11.401	0.0434	0.0121	34474	4.3	1.2	8.7	2.4	10.9	3.0	13.0	3.6	15.2	4.2	17.4	4.8
Kilowatts Required						57	113	140	168	196	224						

Volumetric Rate is based on 100% Volumetric Efficiency. Brake Horsepower/Kilowatts Required is based on 90% Mechanical Efficiency. For Operation below 100 RPM, an auxiliary lubrication system is required. Not all plunger sizes are shown. Contact National-Oilwell for additional information. Spherical Valves must be installed when the pump is fitted with 4.0" (102mm) plungers.

The information and data on this sheet is accurate to the best of our knowledge and belief, but are intended for general information only. Applications suggested for the materials are described only to help readers make their own evaluations and decisions, and are neither guarantees nor to be construed as express or implied warranties of suitability for these or other applications. National Oilwell makes no warranty either express or implied beyond that stipulated in National Oilwell Standard Terms and Conditions of Sale.

Authorized Distributor:



www.nov.com • mission.sales@nov.com
 10000 Richmond, Houston, Texas 77042
 (713)346-7500 (phone) • (713)346-7366 (fax)